

Retrofit Guideline

Commercial Refrigeration Systems – Medium Temperature

R-12, R-401A & R-409A to Solstice[®] N13 (R-450A) & Genetron[®] 134a

Table of Contents

Introduction	1
Refrigerant Comparison	1
R-450A & R-134a are not a “Drop-in” Replacements	2
Retrofit Procedures – Summary	2
Retrofit Procedures – Detailed	
1. Site Survey	2
2. Preparataion	4
3. Retrofit	5
Appendices	
A. Compressors	8
B. Refrigerant Line Sizing	13
C. Control Settings	16
D. Leak Prevention Measures	22
E. Pressure – Temperature Charts	26

Preface

This guideline is based on a retrofit of supermarket refrigeration systems but can be used as a guideline for any commercial refrigeration system retrofit.

As supermarket owners work to comply with regulations, as well as reduce their carbon footprint, existing refrigeration equipment may need to be either replaced or retrofitted with an alternative refrigerant. The selection of a retrofit refrigerant depends, in part, upon retrofit objectives that include factors such as efficiency, first cost, regulatory compliance and capacity.

Technicians may follow equipment manufacturers’ recommendations and Honeywell’s guidelines outlined in this publication to help retrofit existing R-12, R-401A, and R-409A refrigeration systems to R-450A or R-134a.

R-12 is a refrigerant that was typically used for medium temperature supermarket systems. R-12 is a class I CFC refrigerant under the Clean Air Act and as such is regulated under the class I ODS phase out within the clean air act. This includes a ban on production or import of R-12 as of 1995.

R-401A & R-409A are refrigerants employed as replacements for R-12 in medium temperature refrigeration systems. R-401A and R-409A contain Class II HCFC refrigerants and are regulated under the class II ODS phase out within the Clean Air Act regulation. This includes a ban on production or import of applicable HCFCs as of 2020.

R-450A and R-134a are both viable choices for replacement of R-12, R-401A, and R-409A.

- R-450A is an HFO/HFC blend with a low GWP and zero ozone depletion potential.
- R-134a is an HFC with zero ozone depletion potential.

Introduction

The commercial refrigeration industry continues to move away from the use of ozone-depleting and high global warming potential (GWP) refrigerants. Refrigeration contractors and technicians will play a key role in the transition to alternatives through retrofitting. Honeywell has produced this guide to help contractors and technicians better understand the various technical and operational aspects of carrying out retrofit procedures using R-450A or R-134a.

Although the information can be helpful as a general guide, it should not be used as a substitute for the equipment manufacturer's specific recommendations. Also, retrofitting should be considered system-specific.

Since systems can differ in condition and configuration, retrofit actions applied to one system will not necessarily result in the same level of success in another system. For this reason, Honeywell strongly recommends contacting the equipment manufacturer for detailed information on retrofitting the specific model under consideration. Also, review the Safety Data Sheet (SDS) for safety information on the specific refrigerant you choose.

Refrigerant Comparisons

Refrigerant comparisons appear in the chart below.

Refrigerant	Type	Replaces	Ozone Depletion Potential (ODP)	Global Warming Potential (GWP)
ALTERNATIVE REFRIGERANTS				
Solstice® N13 (R-450A)	HFO/HFC Blend R-1234ze R-134a	R-134a R-12, R-401A R-409A	0.0	547
Genetron® 134a (R-134a)	HFC R-134a	R-12 R-409A, R-401A	0.0	1300
RETROFITTED REFRIGERANTS				
R-12	CFC R-12**	NA	1.0	10,200
R-401A (MP-39)	HCFC/HFC Blend R-22* (HCFC) R-152a (HFC) R-124 (HCFC)	R-12	0.037	1330
R-409A	HCFC Blend R-22* (HCFC) R-124 (HCFC) R-142b* (HCFC)	R-12	0.048	1485

* Production and import ceases in 2020

** Production ceased 1995

R-450A & R-134a are not “Drop-in” Replacements

R-450A & R-134a utilize synthetic lubricants. The mineral oil typically contained in R-12, R-401A and R-409A systems will need to be changed. The O-rings in the R-12, R-401A, and R-409A systems may also experience degradation due to the removal of chlorine contained in these refrigerants. Expansion valves will require adjustment and occasional modification or replacement.

The retrofit procedures listed here have been developed by Honeywell to address these issues and to help technicians perform successful retrofits utilizing positive-displacement (reciprocating, rotary, scroll or screw) compressors.

Retrofit Procedures - Summary

A successful retrofit includes several steps to produce a low maintenance and efficient system. The steps outlined below have been developed through the experience of Honeywell’s technical team as well as many of our service company partners. This guide is only a recommendation based on field experience. Refer to individual retailer procedures to ensure adherence to product integrity and other protocols.

The first step is a site survey. A site survey is recommended to identify existing conditions that impact the retrofit as well as identifying system upgrades that can be done cost effectively during the retrofit. A refrigerant retrofit is an ideal time to increase the life cycle and efficiency of the refrigeration system. The survey also identifies components that may need to be replaced or added to match the new refrigerant and to reduce future leaks.

The second step includes activities to prepare for the retrofit. These are activities that can be done prior to the retrofit. Preparation also includes store coordination and procurement of needed parts. This step shortens the down time during the retrofit as well as reducing overall risk.

The final step is the actual retrofit. This is typically started as early in the evening as the store leadership will allow. The retrofit team will typically include a recovery crew, a construction crew for charging and adjustments, a controls expert, and a supervisor. Retrofitting a single parallel system can be done in one night. Fine tuning of superheat may continue into the operating hours on the next day.

Retrofit Procedures - Detailed

Step 1 - Site survey

1. Compressors
 - Record manufacturer, model and serial numbers
 - Identify failed compressors, failed fans, and any capillary control lines
 - Identify discharge temperature mitigation devices (if any)

- If possible, locate refrigeration schedule to assess the load/capacity ratio. This will allow the capacity to be determined with the new refrigerant. See appendix A for detail.

2. System issues

- Walk the store, machine room and roof to identify any items that impact system operation. Some example areas to identify include failed condenser fans, clogged evaporator coils, failed sub coolers, degraded condensers, poor insulation, obsolete components, etc.

3. Review expansion valves and relief valves

- Any non-adjustable expansion valves should be identified. Replacement valves or adjustment kits should be purchased for these valves prior to the retrofit.
- In general, R-12, R-401A and R-409A valves will have a similar capacity (within 20%) when switching to R-450A or R-134a. Expansion valve superheat will require some adjustment.
- When switching refrigerants the pressure acting on the expansion valves will change. This may result in an inability to close or open the valve enough to allow for superheat adjustment. In some cases the power head may need to be changed.
- Ample supplies of power heads and valves should be on-hand during the retrofit.
- When retrofitting from R-401A, R-409A, or R-134a to N13 (R-450A) the relief valve(s) size may need to be increased. Please refer to manufactures literature for sizing guidelines. When retrofitting from R-12 to N13 (R-450A) the relief valve size will be acceptable assuming the valve was sized correctly for the existing equipment. The relief valve will also need to be reviewed when retrofitting from R-401A or R-409A to R-134a. Honeywell does recommend replacing the relief valves in any case to ensure they are in good working order.

4. Identify seals and O-rings for replacement

- Chlorine based refrigerants such as R-12, R-401A and R-409A can result in elastomer seal failure when the chlorine-based refrigerant is removed. There are also common seals that should be replaced for a leak-free system. Refer to Appendix E for recommended seals and O-rings for replacement.

5. Record baseline data

- Record baseline data to identify issues and as a reference for post-retrofit performance
- Refer to survey form at <http://bit.ly/2qasBHi>

6. Line sizes
 - Review refrigerant line sizes, especially horizontal suction and riser lines. The Genetron Properties program is available as a free download on the Honeywell Refrigerants web site and can be used to calculate line sizes. Refer to Appendix B for line size examples.
7. Test oil and refrigerant
 - Test oil to identify any signs of serious system issues
 - If recovered refrigerant is to be used at other stores, or otherwise re-used, it is recommended to test it for purity
8. Forward completed survey form to the customer.

Step 2 - Preparation

1. Store coordination
 - It is recommended to meet with store leader and department managers
 - Items to discuss include
 - i. Retrofit dates and times
 - ii. Store hours
 - iii. Unloading of cases
 - iv. Opportunity for case cleaning
 - v. Food safety (dry ice, keeping doors closed, etc)
2. Order parts and refrigerant
3. Technician training
 - Ensure that technicians are trained on setting superheat using dew point temperature with refrigerants with glide. Refer to Appendix C.
 - Refer to pressure-temperature chart in Appendix E.
 - Ensure that technicians are trained on setting pressure valves based on average evaporator and condenser temperatures when using refrigerants with glide. Refer to Appendix C.
 - Honeywell technical team is available to provide on-site or web-based training

4. System changes
 - Perform any activities identified in the survey that can be safely done before the retrofit. This includes any valves that can be isolated without a system pump down, compressor changes, pilot lines, control adjustments, coil cleaning, etc.
5. Change oil from mineral to POE.
 - In most instances, the lubricant in use with R-12, R-401A, and R-409A is not suitable for use with R-450A or R-134a. A change to a synthetic lubricant is required. Honeywell recommends using a miscible lubricant approved by the compressor manufacturer.
 - Usually (1) full oil change is required
 - Refer to Appendix A for oil change recommendations
6. Change suction and liquid filters and driers.
7. Upgrade controller with R-450A or R-134a pressure / temperature curves as applicable.
8. Leak check and repair.

Step 3 - Retrofit

1. Remind store personnel the day prior to retrofit.
2. Secure food safety (dry ice, plastic sheeting, signs on coolers, etc.)
3. Recover existing refrigerant
 - Use Green Chill guidelines at www.epa.gov/greenchill to recover refrigerant.
4. Record amount of refrigerant removed including refrigerant previously removed.
5. Break vacuum from recovery machine.
6. Replace seals, gaskets, and valves as needed. Refer to Appendix D for recommendations.
7. Replace expansion valves and add adjustment kits as determined in survey.
8. Replace driers and filters.
9. Evacuate system
 - Honeywell recommends evacuating the system to 500 microns from both sides of the system. Attempting to evacuate a system with the pump connected only to the low- side of the system will not adequately remove moisture and non-condensables such as air.

- Micron gauge should be placed as far away from the vacuum pump as possible to get an accurate vacuum reading.
- Remove all restrictions like valve cores and using the shortest hoses possible will speed up the vacuum process.
- Use a good electronic micron gauge to measure the vacuum. An accurate reading cannot be made with an analog refrigeration gauge.
- Repair any leaks.

10. Charge system

- When working with R-450A, it is important to remember that it is a blended refrigerant. It is essential that blended refrigerants be liquid-charged by removing only liquid from the cylinder. **Never vapor charge the system with vapor from an R-400 series refrigerant cylinder.** Vapor-charging may result in a change in the refrigerant composition and unpredictable system performance.
- A liquid charging adapter should be used to control the flow of refrigerant if charging to the suction side to ensure that the liquid is converted to vapor prior to entering the system.
- **NOTE:** To prevent compressor damage, do not charge liquid directly into the suction line of the compressor.
- Systems being charged with R-450A require:
 - Approximately 13% lower charge than R-12
 - Approximately 3% lower charge than R-409A
 - Approximately 1% lower charge than R-401A
- Systems being charged with R-134a require:
 - Approximately 11% lower charge than R-12
 - Approximately 1% higher charge than R-409A
 - Approximately 1% lower charge than R-401A
- Allow conditions to stabilize. If the system is undercharged, add refrigerant in increments of 5 percent by weight of the original charge. Continue until desired operating conditions are achieved.

11. Adjust expansion valves

- Adjusting valves is a very important part of any retrofit. Properly adjusted valves will prevent compressor damage, ensure safe food temperatures, and result in an efficient system.

- Most valves will require some adjustment.
- Refer to step 1 item 3 for details on expansion valves.
- In the absence of specific manufacturer recommendations, a 4 to 6°F superheat for low temperature and 6 to 8°F for medium temperature is recommended.

12. Adjust pressure controls

- All mechanical controls should be reviewed for adjustment. This includes safety controls, EPR valves, holdback valves, etc. Refer to Appendix C prior to making any set point adjustments.
- R-450A has a slight glide. For highest accuracy it is recommended to adjust evaporator and condenser pressures using of an average coil temperature as shown on Honeywell PT charts
- Refer to Appendix C prior to making any set point adjustments for condenser control.

13. Label Components and System

- After retrofitting the system with R-450A, label the system components to identify the refrigerant and specify the type of lubricant (by brand name) in the system. This will help ensure that the proper refrigerant and lubricant will be used to service the equipment in the future.
- Contact Honeywell wholesaler for labels, PT charts, etc.

Appendix A - Compressors

Disclaimer: Some of the following information was obtained from manufacturers' information. Please refer to the manufacturer for updates to the information. In some cases it may be possible that the recommendations are quite conservative.

Refrigerant Oil

Process:

In most instances, the lubricant in use with R-12, R-401A, and R-409A is not suitable for use with R-450A or R-134a and a change to a synthetic lubricant is required. Honeywell recommends using a miscible lubricant approved by the compressor manufacturer. Differences among lubricants make it difficult to assume they are interchangeable. Check with the compressor manufacturer for the correct viscosity grade and brand for the compressor in the system being retrofitted.

If the lubricant is contaminated or an acid test indicates high levels of acidity, then a full lubricant change is warranted.

Recommended process:

1. Remove existing oil from compressor, reservoir, and separator.
2. Measure volume of lubricant removed. This volume will be used as a guide to determine the amount of new lubricant to add.
3. Change lubricant filters if present.
4. Add new lubricant. It is recommended that polyol ester (POE) lubricant be pumped rather than poured to avoid pick-up of atmospheric moisture.
5. Run for 24 hours ensuring all circuits are defrosted and that all coils such as heat reclaim and split condensers are engaged periodically.
6. Test for % of mineral oil using oil refractometer. 95% synthetic is preferred.
7. Repeat if needed.

Systems charged with POE lubricant should not be left open to the atmosphere for more than 10 to 15 minutes. This is due to the moisture absorbing nature of POE oil.

Note that evacuation will not remove moisture from POE lubricant. A solid core filter drier designed for moisture removal is the only effective means to remove moisture from POE lubricant.

Appendix A - Compressors

Carlyle reciprocating compressors

Per [O6deaguide.pdf](#), Lit. No. 574-069 Rev B 6/04 the following POE oils are approved for use on Carlyle O6D/E compressors.

Manufacturer	Brand Name
Castrol ICI EMKARATE CPI	E68 RL68H SOLEST 68
Mobil Arctic† Castrol†	EAL 68 SW 68

Copeland reciprocating compressors

Per [Emerson 93-11 R32 \(1/16\)](#) Copeland recommends POE-32 for use with Solstice N40 (R-450A or R-134A)**. Visit Emerson web site for latest approved lubricants. POE-32 includes:

- Polyolester Oil
(Copeland Ultra 32-3MAF) - Preferred
- Lubrizol Emkarate RL32-3MAF
- Everest 32-3MAF
- Parker EMKARATE RL32-3MAF/
(Virginia) LE323MAF
- Nu Calgon 4314-66/EMKARATE RL32-3MAF

Approved for 'top off' only:

- Everest 22 CC
- Copeland Ultra 22 CC
- Mobil Arctic 22 CC)
- (Last three are approved for top off only)

Appendix A - Compressors

Compressor Compatibility

Copeland reciprocating compressors

Older Copeland reciprocating compressors are recommended to be replaced with new models. This is because the older models were never qualified for use with HFO refrigerants and POE oil. These compressors can be identified by an “R” in the second letter in the model. For example, a 4RA3-1000-TSK compressor is not qualified for use with POE oil.

Compressor replacement should occur prior to any change to synthetic oil.

Newer model Discus compressors are approved for use with POE oil and R-450A or R-134a.

The compatible models are:

- 2D all
- 3D manufactured after 1999
- 4D & 6D manufactured after April 2003

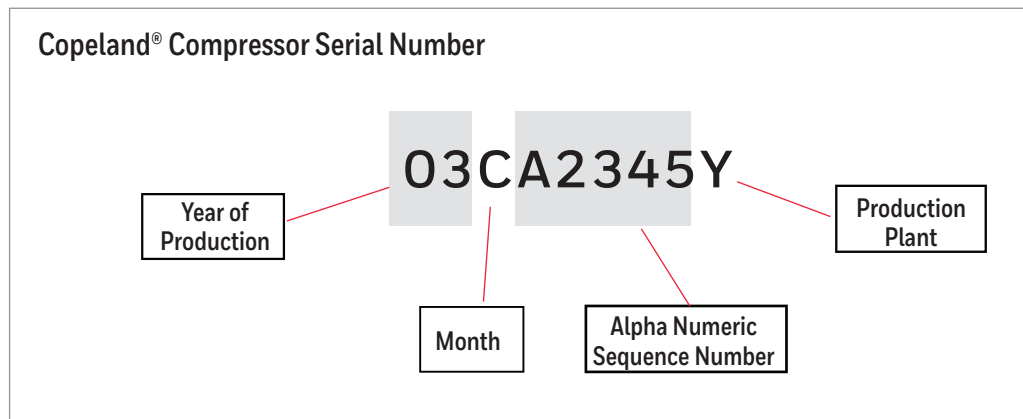

3D compressor Moduload systems should be checked for applicability. Retrofit kits are available.

Blocked suction capacity control on 4D and 6D compressors is compatible with POE oil and R-450A or R-134a.

Refer to Emerson application engineering bulletin [CC7.26.5/0117E](#) for information on recommended crankcase heaters, suction accumulators, etc.

Appendix A - Compressors

Carlyle reciprocating compressors

Carlyle began using a higher flow oil pump in June 1994. This pump is recommended in order to prevent oil failures when using synthetic oils. It is recommended that compressors with serial numbers beginning with 0694 or older be retrofitted with the high flow oil pump.

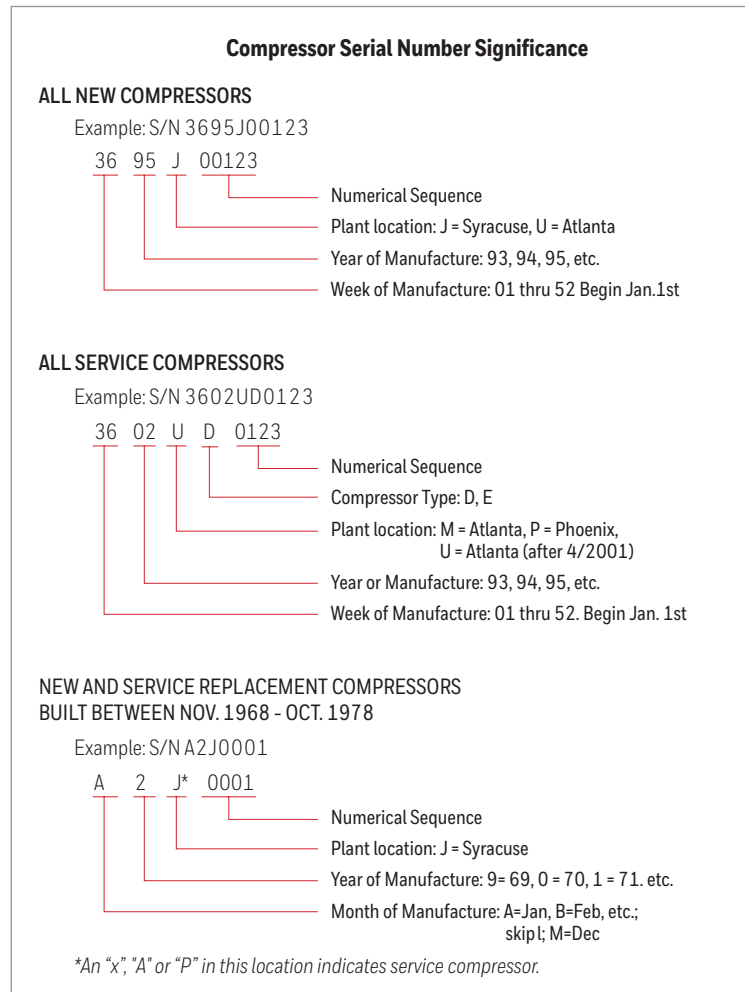

Per [O6deaguide.pdf](#), Lit. No. 574-069 Rev B 6/04 Carlyle serial number/date reference

Per O6D/E Pocket Service Guide, page 8, literature number O20-611 at www.carlylecompressor.com

Carlyle screw compressors

Carlyle 74mm screw compressors have a low risk of a compressor seal refrigeration leak during retrofits.

Appendix A - Compressors

Discharge Temperature Mitigation

With R-450A or R-134a running in medium temperature systems there will be no need for discharge temperature mitigation.

Capacity and Efficiency

A thermodynamic comparison of refrigerants shows R-134a and R-450A to have similar characteristics to legacy refrigerants.

The chart below uses R-12 as a baseline since R-401A and R-409A systems are typically original R-12 systems.

Refrigerant	GWP	Capacity	Efficiency
R12	10200	100%	100%
R401A	1130	113%	101%
R409A	1485	114%	101%
R134a	1300	101%	99%
R450A	547	88%	99%

Refrigerant comparisons

+20°F SST, +70°F SCT, +45°F RGT

Adding sub cooling during a retrofit can increase efficiency and provide additional capacity. Contact Honeywell technical support for assistance.

Appendix B - Refrigerant Line Sizing

Introduction

Refrigerant line sizes in a typical supermarket system consist of the compressor discharge, condenser return, and individual circuit liquid and suction lines.

The correct line sizes help to ensure a properly running system. Prior to a retrofit it is recommended to review horizontal and vertical suction line sizes.

This review will identify any line size changes needed due to the new refrigerant and/or existing line size design concerns.

The correct design of these line sizes ensures that:

1. The suction line size is large enough to result in a pressure drop that is compatible with the design. Designers will normally account for a suction line pressure drop. (The design pressure drop can be determined by a review of the refrigeration schedule, contact Honeywell technical services for assistance).
2. The line size is small enough to result in refrigerant velocity sufficient to ensure oil is returned to the compressor. This is especially important on vertical risers.

The following chart shows the high suction line velocities (a benefit) when using R-134a or R-450A as well as the R-134a and R-450A pressure drop which is similar to other refrigerants.

With these characteristics it is generally true that a system that had proper line sizing before the retrofit will work well with R-134a or R-450A.

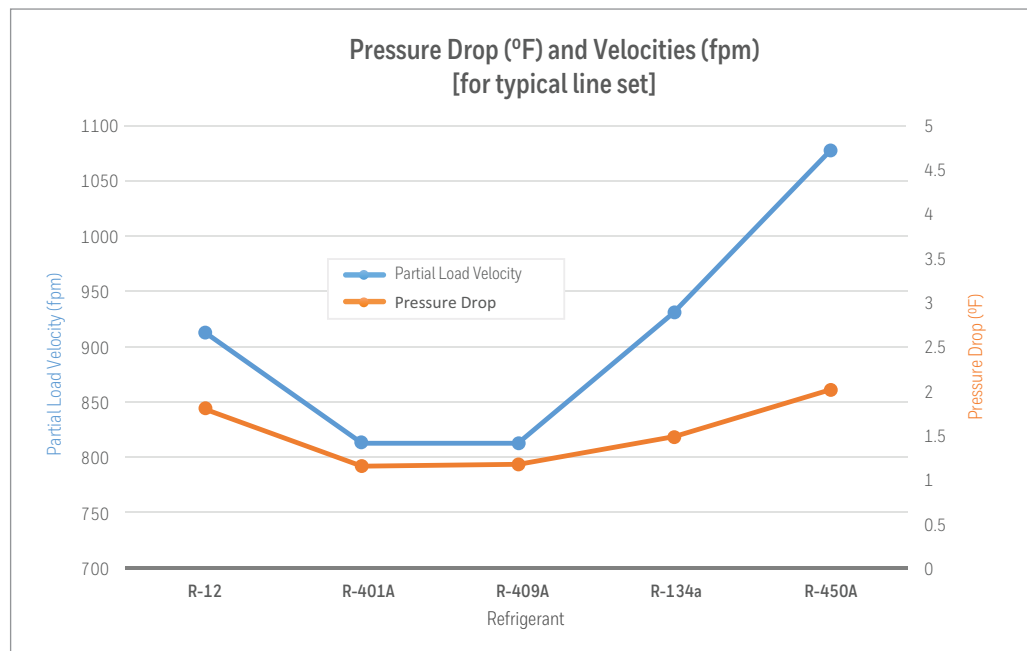

Appendix B - Refrigerant Line Sizing

Suction Line Sizes

ASHRAE recommends horizontal suction line refrigerant velocities greater than 500 ft/min for horizontal lines and greater than 900ft/min for vertical risers. A vertical suction riser should maintain a minimum of 900 fpm at the lowest load condition expected for the system.

On a typical refrigeration system the saturated condensinsg temperature can vary from 60°F up to 120°F. The capacity of refrigerant at the lower temperatures can reduce required flow rate as much as 35%. In addition, the load for the display cases is significantly reduced when humidity is low in lower ambient conditions.

The cumulative effect of the increased capacity and reduced load in lower ambient results in a flow reduction approaching 50%.

It is recommended to use the reduced refrigeration load when calculating suction riser velocities. In locations with wide extremes of temperature and humidity, a value of 50% should be used.

As long as horizontal suction lines are properly sloped in the direction of the compressor, oil can be transported on horizontal runs with normal design velocities. Due to this the 100% design loads can be used when calculating horizontal line sizes.

Pipe size calculation:

The [Genetron Properties](http://www.Honeywell-refrigerants.com) program is available as a free download from www.Honeywell-refrigerants.com and can be used to calculate line sizes.

Step 1: Deterermine circuit design temperatures and refrigeration load.

Step 2: Determine existing line sizes.

Step 3: Choose Cycles in the Genetron software.

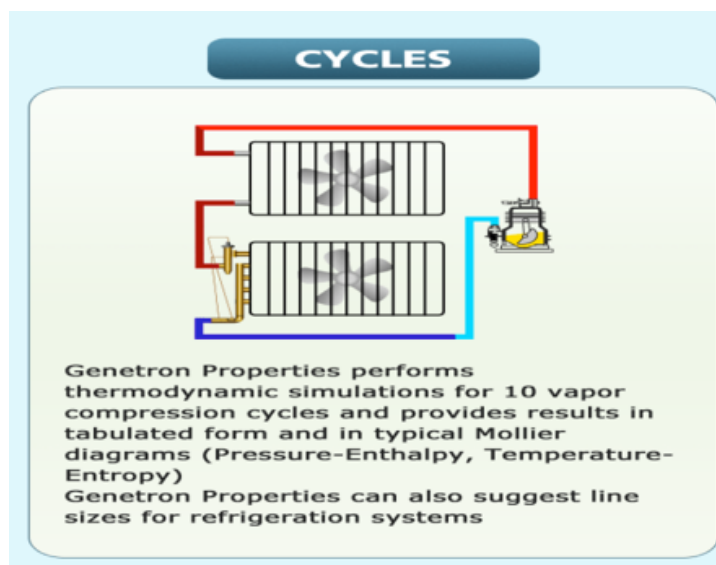

Appendix B - Refrigerant Line Sizing

Step 4: Select line sizing

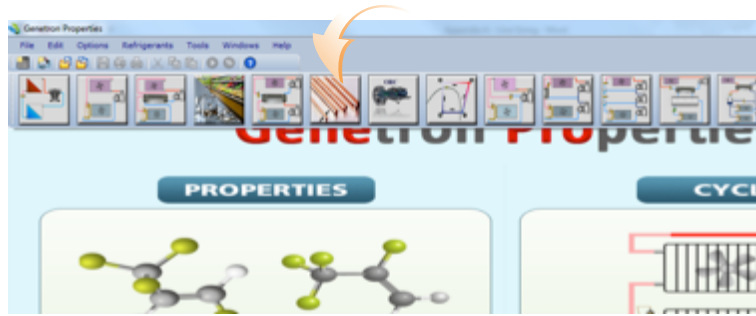

Step 5: Calculate the drop in saturation temperature and velocity for the horizontal lines and risers.

Note: When calculating riser temperature rise, enter a main line length of zero.
Contact Honeywell technical support with any questions.

Appendix C - Control Settings

Control Settings with R-450A

- Superheat
- Liquid subcooling
- Evaporator Pressure Regulator (EPR)
- Condenser

Introduction

The proper setting of superheat, subcooling and pressures is critical to a well-performing system. During a retrofit it will be necessary to check and adjust mechanical control valves.

Superheat

Procedure:

1. Use a thermometer to determine the actual temperature at the evaporator coil outlet.
2. Use gauges to determine the pressure at the evaporator coil outlet.
3. Using this pressure, determine the dew temperature using the “dew” column of the PT chart.
4. Calculate superheat.

Superheat = actual temperature at evaporator coil outlet - dew temperature from PT chart.

Example: Determine the superheat on a system which uses Solstice N13 (R-450A) when the pressure at the Evaporator coil outlet reads 15 psig and the actual temperature at the coil outlet is 30°F.

1. Actual temperature at coil outlet = 30°F
2. Pressure = 15 psig
3. Find 15 psig in the pressure column of the PT chart and read across to find the dew temperature at that pressure. In the following chart we see the dew temperature at 15 psig is 22°F.
4. Calculate superheat

$$\text{Superheat} = 30^{\circ}\text{F} - 22^{\circ}\text{F}$$

$$\text{Superheat} = 8^{\circ}\text{F}$$

Pressure (psig)	Solstice N13 (R-450A)		
	Temperature		
	Avg	°F Bubble	Dew
5	3	2	3
10	13	12	13
15	21	21	22
20	29	28	29
22	31	31	32

Appendix C - Control Settings

Subcooling at Condenser Outlet

Procedure:

1. Use gauges to determine the pressure at the outlet of the condenser
2. Using this pressure determine the bubble temperature using the “bubble” column of the PT chart.
3. Use a thermometer to get the actual temperature at the same point on the condenser outlet.
4. Calculate sub cooling.

Sub cooling = bubble temperature from PT chart - actual temperature at condenser coil outlet.

Example: Find the amount of subcooling on a system using Solstice N13 (R-450A) when the condenser outlet pressure is 150 psig and the condenser outlet temperature is 110°F.

1. Outlet pressure is 150 psig
2. Actual temperature of pipe is 110°F degrees
3. Find 150 psig in the pressure column of the PT chart and read across to find the bubble temperature at that pressure. In chart to the right, we see the temperature at 150 psig is 120°F.
4. Calculate subcooling

$$\text{Subcooling} = 120^{\circ}\text{F} - 110^{\circ}\text{F}$$

$$\text{Subcooling} = 10^{\circ}\text{F}$$

Pressure (psig)	Solstice N13 (R-450A)		
	Temperature		
	Avg	°F Bubble	Dew
140.0	116.1	115.5	116.6
145.0	118.3	117.7	118.9
150.0	120.5	120	121
155.0	122.6	122.1	123.2
160.0	124.7	124.1	125.2

Note: The same procedure can be used to determine subcooling on the liquid line exiting a subcooler expansion valve inlet, etc.

Appendix C - Control Settings

Evaporator Pressure Regulator (EPR)

Procedure:

1. Determine desired suction temperature at the EPR valve based on design data for the fixture. This can be found on the refrigeration schedule or manufacturer specification sheet.
2. Use gauges to measure the pressure on the fixture side of the EPR valve.
3. Using this pressure find the average temperature column from the PT chart to determine the current setting of the EPR valve.
4. Adjust valve to match required fixture pressure. Some adjustment from the design set point will be necessary based on system pressure drop and other factors.

Example: Set the EPR valve on a circuit which uses Solstice N13 (R-450A) when the pressure at the EPR reads 24 psig and the required fixture suction temperature is 30°F.

1. Desired fixture suction temperature is 30°F.
2. Pressure on the fixture side of valve is 24 psig.
3. Using the pressure column on the PT chart gives an average fixture temp of 34°F.

Pressure (psig)	Solstice N13 (R-450A)		
	Temperature		
	Avg	°F Bubble	Dew
15	21	21	22
20	29	28	29
21	30	29	31
22	31	31	32
24	34	33	35
26	37	36	37

4. The EPR valve should be adjusted to a pressure of 21 psig to match the 30°F required by the fixture.

Pressure (psig)	Solstice N13 (R-450A)		
	Temperature		
	Avg	°F Bubble	Dew
15	21	21	22
20	29	28	29
21	30	29	31
22	31	31	32
24	34	33	35
26	37	36	37

Appendix C - Control Settings

Condenser Pressure Control

There are three main methods of condenser fan / pressure control. These are

- A. Condensing Pressure
- B. Drop leg temperature
- C. Temperature difference (TD)

A: Pressure control

The condensing pressure is sensed and compared to the setting. Fans are cycled to achieve this setting.

For refrigerants with minimal glide, such as R-450A, the average temperature should be used for greatest accuracy.

Example: A condenser pressure setting of 104°F saturated condensing pressure. Determine the corresponding pressure setting for R-450A.

1. On the PT chart find the pressure corresponding to an average temperature of 104°F.
2. This equals a 115 psig setting.
3. The mechanical or electronic fan control should be set to 115 psig.

Pressure (psig)	Solstice N13 (R-450A)		
	Temperature		
	Avg	°F Bubble	Dew
100	96	95	96
105	99	98	99
110	101	101	102
115	104	103	105
120	107	106	107
125	109	108	110
130	111	111	112

B: Drop leg temperature control

The temperature of the condenser outlet piping is sensed and compared to the setting. Fans are cycled to achieve this setting.

For refrigerants with glide, the temperature of the refrigerant leaving the condenser is lower than the average value across the entire coil. Due to this the setting should be changed to reflect the average coil temperature.

Example: A setting to maintain a 90°F condenser outlet pipe temperature for refrigerants without glide is desired. Determine the temperature setting for R-450A.

Appendix C - Control Settings

Refer to chart below:

1. Find the average temperature corresponding to the temperature setting.
2. Find the Bubble temperature in the same row on the PT chart.

The new setting will be the bubble temperature for the average pressure.

New setting = 89.5°F

Note that R-450A has very little glide. Due to this the impact of using the bubble vs. average temperatures is minimal.

Pressure (psig)	Solstice N13 (R-450A)		
	Temperature		
	Avg	°F Bubble	Dew
80.0	83.8	83.2	84.4
90.0	90.0	89.5	90.6
100.0	95.9	95.3	96.5

C: Temperature difference (TD) control

The condenser design and the outdoor ambient temperature are used to calculate the condenser pressure setting. This setting will change as the ambient changes.

Condenser setting = current ambient + condenser design TD.

Example: For a condenser designed for 10 degree temperature difference on a 94 degree day.

1. Condenser setting = ambient + TD
 - a. = 94°F + 10°F
 - b. = 104°F
2. Reading the average pressure corresponding to 104°F gives a pressure setting of 115 psig.
3. The electronic fan control should be controlling to a value of 115 psig. Contact retailer for specific settings. Some retailers will lower the TD setting to achieve increased subcooling.

Pressure (psig)	Solstice N13 (R-450A)		
	Temperature		
	Avg	°F Bubble	Dew
105.0	98.7	98.1	99.3
110.0	101.4	100.8	102.0
115.0	104.0	103.4	104.6
120.0	106.6	106.0	107.1

For mechanical controls simply convert fan cycling schedule from pressure to temperature (original gas). Find this temperature in the average column on the R-450A PT chart. Use the corresponding pressure at that average temperature.

Appendix C - Control Settings

Note for pressure and TD control methods

Some electronic controllers may use the bubble temperature (instead of average) for control. This will lead to a higher effective set point.

It is recommended to make set points as described in the examples above and monitor the system to see if it controls as expected.

If control performance is not correct it will be necessary to either adjust the set points or put offsets into the sensors to account for the difference between bubble and average temperatures.

Contact Honeywell technical team or the specific controller technical teams for assistance.

Appendix D – Leak Prevention Measures

Introduction

During the retrofit from an HCFC to an HFO or HFC refrigerant, the elimination of chlorine from the refrigerant, as well as the solvent nature of the required synthetic oils can contribute to system leaks.

These leaks are concentrated in component elastomeric O-rings and seals.

When retrofitting from an HCFC to an HFO refrigerant, the material compatibility and the condition of existing seals and gaskets should also be taken into account. Heat set, compression set, and seal shrinkage can all impact the condition of an existing seal or gasket. When the system is then put under vacuum, the sealing device can be displaced, creating the potential for leakage.

It is recommended to replace the entire component, or the O-ring/seal, in the following areas.

- Schrader valves and caps
- Receiver level indicators and alarms
- Heat reclaim and condenser splitting valves
- Evaporator Pressure Regulators (EPRs)
- Solenoid Valves
- Pilot hoses
- Ball valves

Some ball valve manufacturers have an available retrofit cap that eliminates the need to replace the O-rings.

A retrofit is also a good time to replace valves that are beyond their life-cycle.

Some valves will not have replacement seals available and will need to be replaced.

Appendix D – Leak Prevention Measures

Example Valves with Gasket and O-ring Locations Evaporator Pressure Regulator

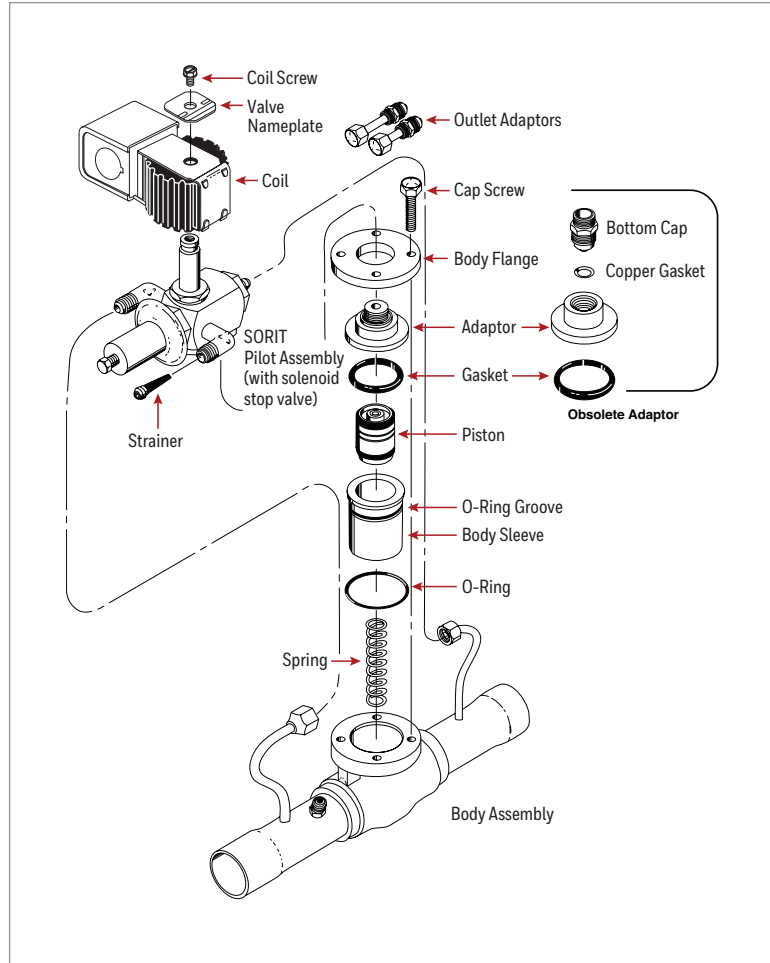

Appendix D – Leak Prevention Measures

Heat Reclaim Valve

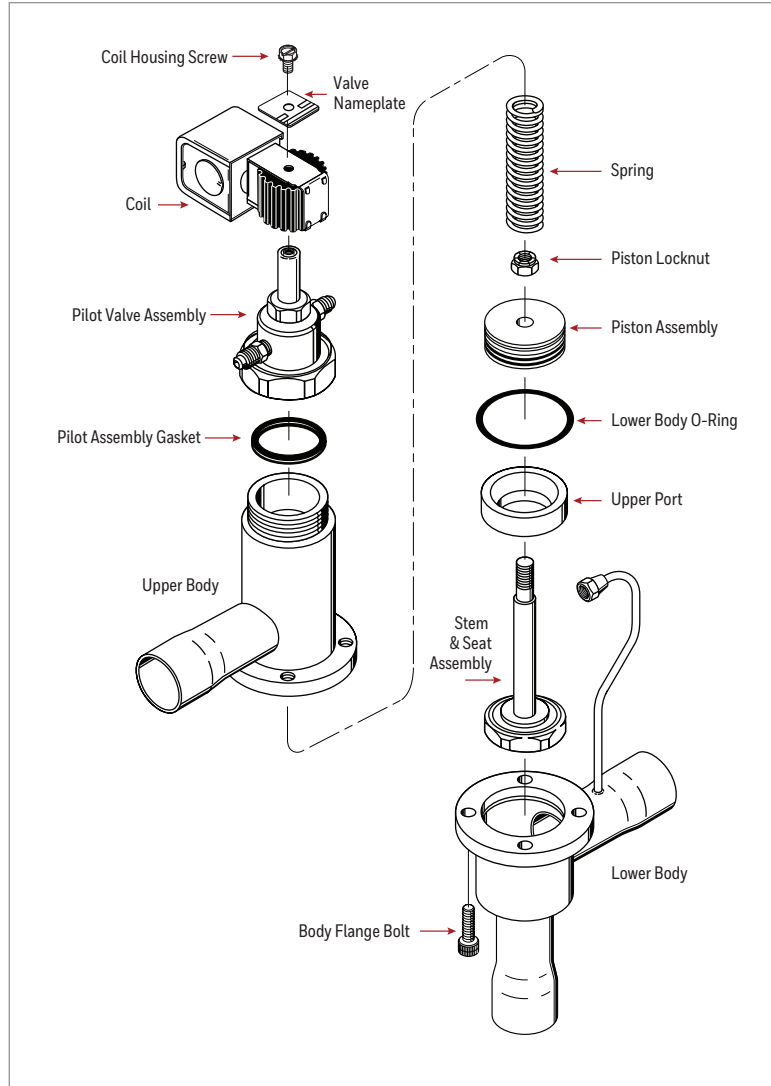

Appendix D – Leak Prevention Measures

Solenoid Valve

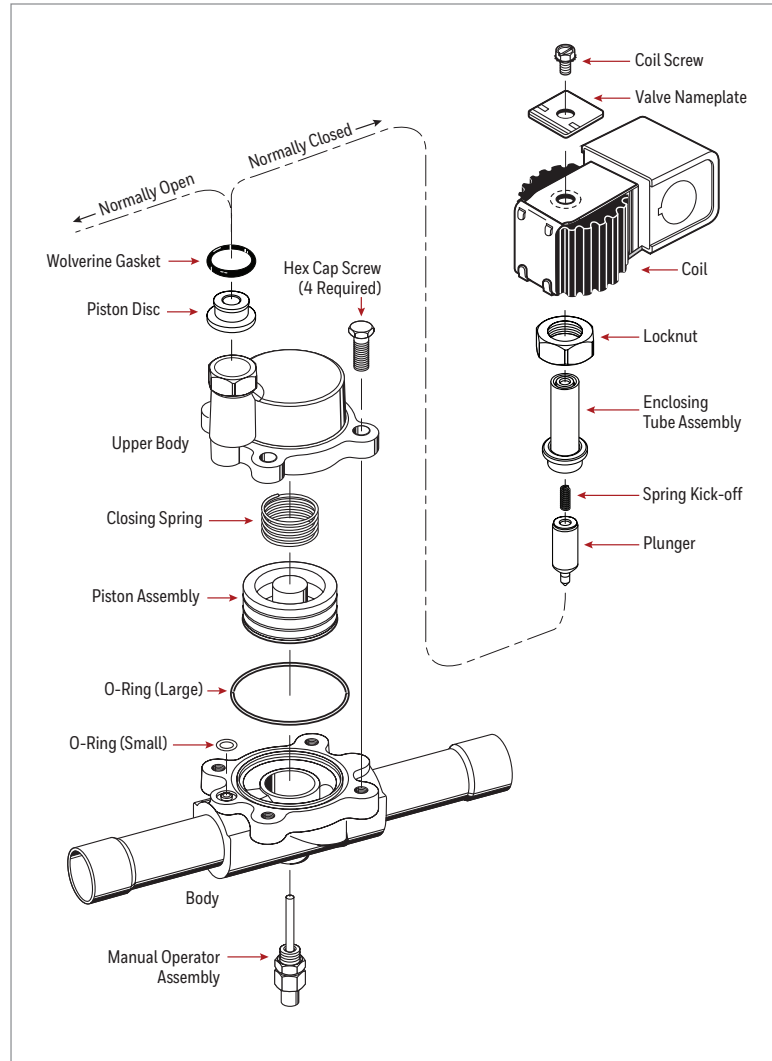

Appendix E - Pressure/Temperature Chart

Solstice N13 (R-450A)

Pressure (psig)	Temperature (°F)		
	Average	Bubble	Dew
0.0	-10.0	-10.0	-9.0
5.0	3.0	2.0	3.0
10.0	13.0	12.0	13.0
15.0	21.0	21.0	22.0
20.0	29.0	28.0	29.0
22.0	31.0	31.0	32.0
24.0	34.0	33.0	35.0
26.0	37.0	36.0	37.0
28.0	38.9	38.4	39.5
30.0	41.3	40.7	41.9
32.0	43.6	43.0	44.2
34.0	45.8	45.2	46.4
36.0	47.9	47.3	48.5
38.0	50.0	49.4	50.6
40.0	52.0	51.4	52.6
42.0	53.9	53.4	54.5
44.0	55.8	55.3	56.4
46.0	57.7	57.1	58.3
48.0	59.5	58.9	60.1
50.0	61.3	60.7	61.8
55.0	65.5	64.9	66.1
60.0	69.5	68.9	70.1
70.0	77.0	76.4	77.5
80.0	83.8	83.2	84.4
90.0	90.1	89.5	90.6
100.0	95.9	95.3	96.5
105.0	98.7	98.1	99.3
110.0	101.4	100.8	102.0

Pressure (psig)	Temperature (°F)		
	Average	Bubble	Dew
115.0	104.0	103.4	104.6
120.0	106.6	106.0	107.1
125.0	109.0	108.5	109.6
130.0	111.4	110.9	112.0
135.0	113.8	113.2	114.3
140.0	116.1	115.5	116.6
145.0	118.3	117.7	118.9
150.0	120.5	119.9	121.0
155.0	122.6	122.1	123.2
160.0	124.7	124.1	125.2
165.0	126.7	126.2	127.3
170.0	128.7	128.2	129.3
175.0	130.7	130.2	131.2
180.0	132.6	132.1	133.2
185.0	134.5	134.0	135.0
190.0	136.3	135.8	136.9
195.0	138.2	137.6	138.7
200.0	139.9	139.4	140.5
205.0	141.7	141.2	142.2
210.0	143.4	142.9	143.9
215.0	145.1	144.6	145.6
220.0	146.8	146.3	147.3
230.0	150.0	149.5	150.5
240.0	153.2	152.7	153.7
250.0	156.2	155.7	156.7
260.0	159.2	158.7	159.7
270.0	162.1	161.6	162.6
280.0	164.9	164.4	165.4

Appendix E - Pressure/Temperature Chart

Genetron 134a

Pressure (psig)	Temperature (°F)	Pressure (psig)	Temperature (°F)
0.0	-14.9	115.0	95.5
5.0	-3.1	120.0	98.0
10.0	6.7	125.0	100.4
15.0	14.9	130.0	102.7
20.0	22.2	135.0	105.0
22.0	24.9	140.0	107.2
24.0	27.4	145.0	109.4
26.0	29.9	150.0	111.5
28.0	32.3	155.0	113.6
30.0	34.6	160.0	115.6
32.0	36.8	165.0	117.6
34.0	38.9	170.0	119.6
36.0	41.0	175.0	121.5
38.0	43.0	180.0	123.3
40.0	45.0	185.0	125.2
42.0	46.9	190.0	127.0
44.0	48.7	195.0	128.7
46.0	50.5	200.0	130.4
48.0	52.3	205.0	132.1
50.0	54.0	210.0	133.8
55.0	58.1	215.0	135.5
60.0	62.0	220.0	137.1
70.0	69.2	230.0	140.2
80.0	75.9	240.0	143.3
90.0	82.0	250.0	146.3
100.0	87.7	260.0	149.2
105.0	90.4	270.0	152.0
110.0	93.0	280.0	154.7

Worldwide Sales Offices

United States

Honeywell International
115 Tabor Road
Morris Plains, NJ 07950
Phone: 800-631-8138

Latin America/Caribbean

Honeywell Chemicals Mexico
Constituyentes 900
Col. Lomas Atlas
C.P. 950, Mexico DF
Mexico
Phone: 52-55-5549-0303
Fax: 52-55-5544-9803

Canada

Honeywell Asca. Inc.
3333 Unity Drive
Mississauga, Ontario
L5L 3S6
Phone: 905-608-6325
Fax: 905-608-6327

Asia-Pacific

Honeywell (China) Co., Ltd.
No 430, Li Bing Road
Zhang Jiang Hi-Tech Park
Pudong New Area, Shanghai 201203
China
Phone: 86-21-2894-2000
Fax: 86-21-5855-2719

Honeywell Japan Inc.
New Pier Takeshiba
South Tower Building, 20th Floor
1-16-1 Kaigan, Minato-ku,
Tokyo 050022, Japan
Phone: 81-3-6730-7000
Fax: 81-3-6730-7221

Honeywell Chemicals, Korea
6F Janghakjaedan, B/D 44-1
Bangpo-Dong, Seocho-Ku
Seoul 137040, Korea
Phone: 8-22-595-0204
Fax: 8-22-595-4964

Honeywell Specialty Chemicals
(Singapore) Pte. Ltd.
17 Changi Business Park Central 1
Honeywell Building
Singapore 486073
Phone: 65-6355-2828
Fax: 65-6783-2947

Honeywell International
71 Queens Road,
Ground Floor
Melbourne, Victoria 3004
Australia
Phone: 61-3-9529-1411
Fax: 61-3-9510-9837

Northern and Central Europe

Honeywell Belgium NV
Haasrode Research Park
Grauwmeer 1
3001 Heverlee
Belgium
Phone: 32-16-391-212
Fax: 32-16-391-371

Southern Europe, Middle East and Africa

Honeywell Fluorine Products Italia Srl
V. Le Milanofiori El
20090 Assago - MI - Italia
Phone: 0039-02-89259601
Fax: 0039-02-57500815

Customer Service

To place an order from
anywhere in the Continental United
States, Hawaii
and the Caribbean:
Phone: 800-522-8001
Fax: 800-458-9073

Canada:
Phone: 800-553-9749
Fax: 800-553-9750

Northern and Central Europe
Phone: +32-16-391-209
Phone: +32-16-391-216
Fax: +32-16-391-235

Southern Europe,
Middle East and Africa
Phone: +39-02-9379-6777
ext. 24 / 25 and 26
Fax: +39-02-9379-6761

Outside these areas:
Phone: 1-973-455-6300
Fax: 1-973-455-2763

For more information:
www.honeywell-refrigerants.com

Honeywell Refrigerants
115 Tabor Road
Morris Plains, NJ 07950
Phone: 1-800-631-8138

Although Honeywell International Inc. believes that the information contained herein is accurate and reliable, it is presented without guarantee or responsibility of any kind and does not constitute any representation or warranty of Honeywell International Inc., either expressed or implied. A number of factors may affect the performance of any products used in conjunction with user's materials, such as other raw materials, application, formulation, environmental factors and manufacturing conditions among others, all of which must be taken into account by the user in producing or using the products. The user should not assume that all necessary data for the proper evaluation these products are contained herein. Information provided herein does not relieve the user from the responsibility of carrying out its own tests and experiments, and the user assumes all risks and liabilities (including, but not limited to, risks relating to results, patent infringement, regulatory compliance and health, safety and environment) related to the use of the products and/or information contained herein.

Genetron and Solstice are registered trademarks of Honeywell International Inc.



1950 FP Ref v8 | August 2018
© 2018 Honeywell International Inc.

Honeywell